

# Magnetic fastener for connecting rails

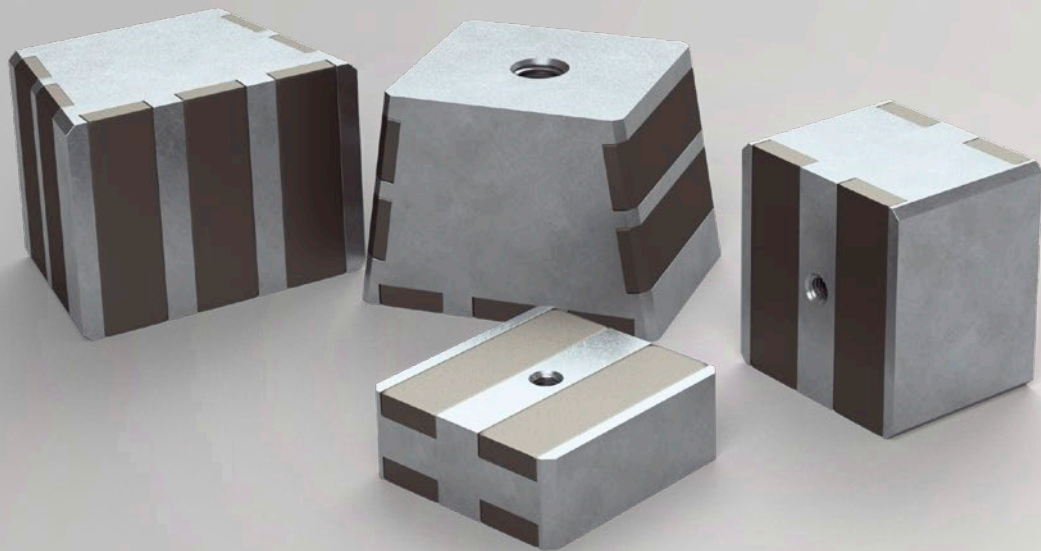

# Our products from the division BUILDING SOLUTIONS

## SERVICES

- » On-site tests -> we ensure that your requirements are properly covered by our planning.
- » Test reports -> for your safety and documentation.
- » Trainings -> the knowledge of your employees from planning and production is enhanced by our experts on site, online or via webinar.
- » Planning support -> latest design software, planning documents, CAD data and much more can be downloaded any time from [www.philipp-group.de](http://www.philipp-group.de).

## HIGH DEMANDS ON PRODUCT SAFETY AND PRACTICALITY

- » Close cooperation with notified bodies and - if necessary - approval of our solutions.

## TECHNICAL DEPARTMENT

- » Our expert-team will support you at any time during your planning phase with detailed advice.

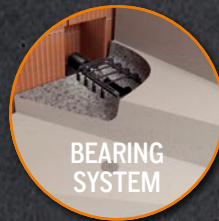
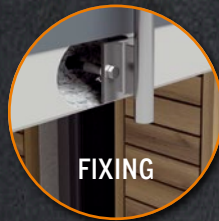
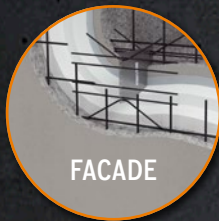
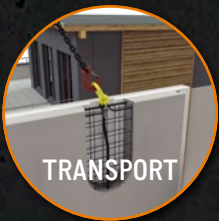

## CONTENT

<b>MAGNETIC FASTENER FOR CONNECTING RAILS</b>	<b>Page</b>	<b>4</b>
Magnetic fastener	Page	4
Possible combinations	Page	4
<b>NOTES ON THE USE OF MAGNETS</b>	<b>Page</b>	<b>4</b>
Handling	Page	4
Temperature	Page	4
Effect	Page	4
Responsibility	Page	4
<b>APPLICATION OF THE MAGNETIC FASTENER</b>	<b>Page</b>	<b>5</b>
84MAX20 und 84MAX40 (e.g. for Power Duo System - 20 mm)	Page	5
84MAX70 (e.g. for Power Duo System - 70 mm)	Page	6

# Magnetic fastener for connecting rails

## MAGNETIC FASTENER FOR CONNECTING RAILS

The Magnetic fastener for connecting rails supports an easy and fast attachment of various connecting rails to a steel formwork. They are simply inserted into the connecting rails and fix them in the desired position to the formwork. A correction of the position is still possible at any time.

If the magnetic fasteners remain on the formwork during demoulding, they can be removed easily with the help of the integrated thread.

For connecting rails up to 1.25 m long, use 2 magnetic fasteners each. For lengths up to 2.5 m, use 3 magnetic fasteners each. Nevertheless, depending on the installation situation, it may be necessary to use additional magnetic fasteners.

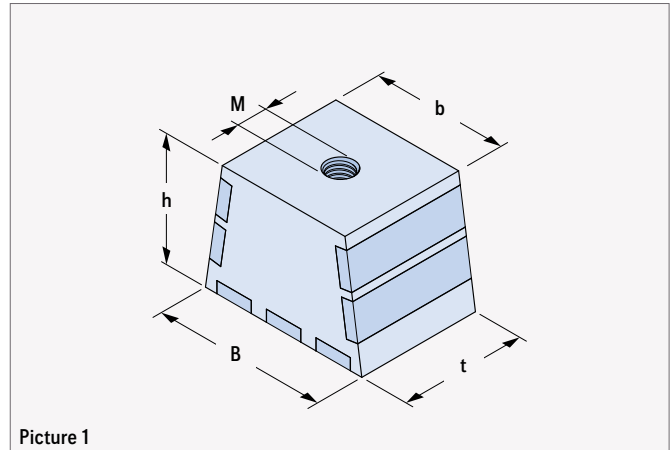

TABLE 1: MAGNETIC FASTENER

Ref. no.	Adhesion (kg)	Dimensions				
		h (mm)	B (mm)	b (mm)	t (mm)	M
84MAX20	100	20	50	47	50	M 6
84MAX40	100	40	50	47	50	M 6
84MAX70	150	50	69	54	50	M 12

TABLE 2: POSSIBLE COMBINATIONS

Ref. no.	Connecting rails						
	constructive			approved			
	Rail depth 20 mm	Rail depth 40 mm	Rail depth 70 mm	Power Duo System - 20 mm	Power Duo System - 70 mm	Power OS	Power One
84MAX20	●	-	-	●	-	●	-
84MAX40	-	●	-	-	-	-	●
84MAX70	-	-	●	-	●	-	-



## NOTES ON THE USE OF MAGNETS

### HANDLING!

Improper usage could cause skin bruises and blood effusions. Caused by the high impact speed parts of the magnets can be damaged and hurt the user. Magnets should be out of the reach of children. Swallowing of the magnets can cause severe medical problems. Persons with pacemakers are suggested to keep a certain safety distance to strong magnets. Direct contact with magnetic materials can also cause allergic reactions (e.g. against ceramic and metallic materials such as zinc, nickel or plastic).

### TEMPERATURE!

Please note that the magnets have a maximum operating temperature of 80 °C. At temperatures above 80 °C they may permanently lose some of their adhesive force.

### EFFECT!

Please notice that magnetic fields could delete data of hard disks, cards with magnetic straps etc. Electronic and mechanic components alike pacemaker, watches, counter, compass, screens can be influenced or destroyed. Please keep a safe distance to these objects of at least one meter.

### RESPONSIBILITY!

The magnets are coated to protect them. The coating can be exposed by the normal wear of magnets. By collision of magnets chipping of the coating may appear. But the exposure of the coating does not reduce the capacity of the magnet or should be a reason for any complaint. Mechanical actions such as welding or grinding are to be avoided in any case.

## APPLICATION OF THE MAGNETIC FASTENER: 84MAX20 AND 84MAX40 (E.G. FOR POWER DUO SYSTEM - 20 MM)

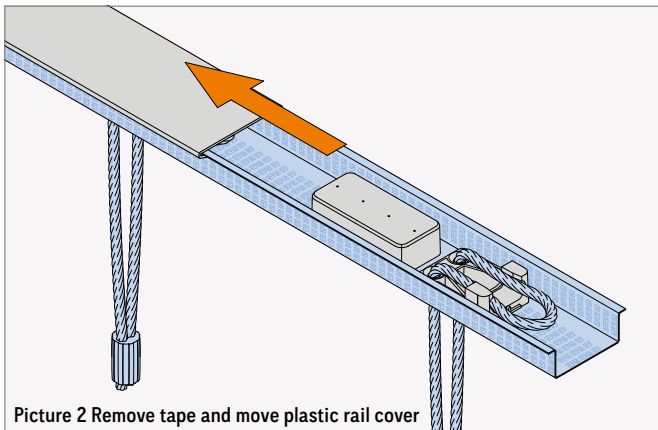

Picture 2 Remove tape and move plastic rail cover

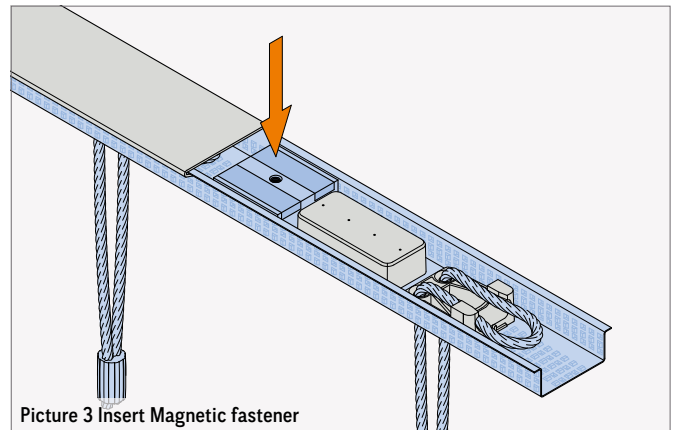

Picture 3 Insert Magnetic fastener

In order to insert the Magnetic fasteners into the rail the sealing (tape) at the end of the rails has to be removed. Then, the rail cover

is moved slightly so that the Magnet fasteners can be placed in a free area in the sheet metal profile.

### INSTALLATION OF MULTIPLE CONNECTING RAILS

If multiple rails are installed in a row, only one Magnetic fastener is required per rail joint. In this case, the rail joint must be sealed again with adhesive tape after installation on the formwork.

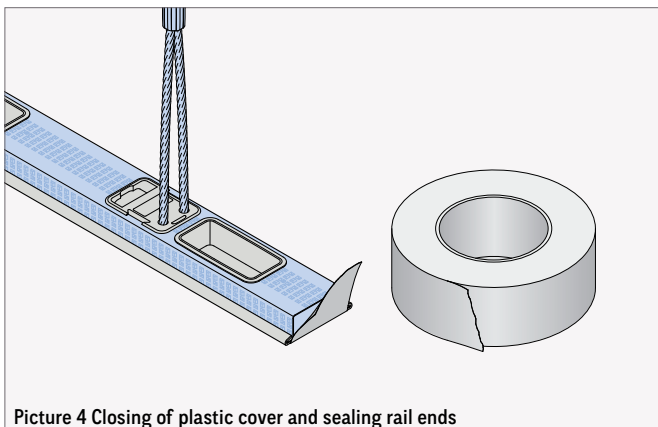

Picture 4 Closing of plastic cover and sealing rail ends

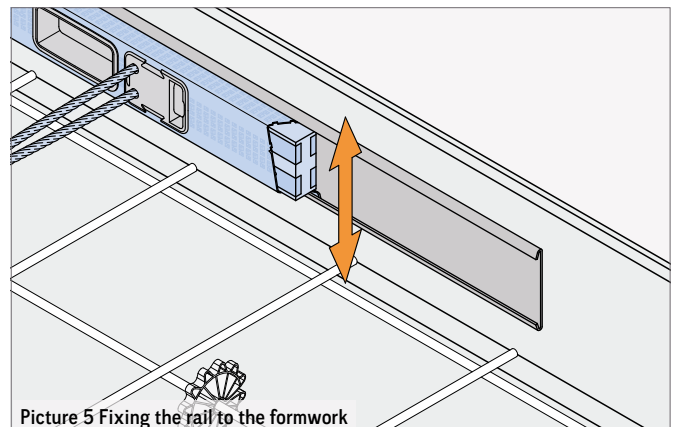

Picture 5 Fixing the rail to the formwork

The rail cover is now put back in its original position and the rail ends are sealed tightly (adhesive tape).

Now, the rail with the Magnetic fasteners can be attached to the steel formwork. A correction of the rail position is possible at all times without any problems.

### REMOVING THE COVER

When removing the plastic cover, avoid damaging the Magnetic fasteners with tools (e.g. hammer).

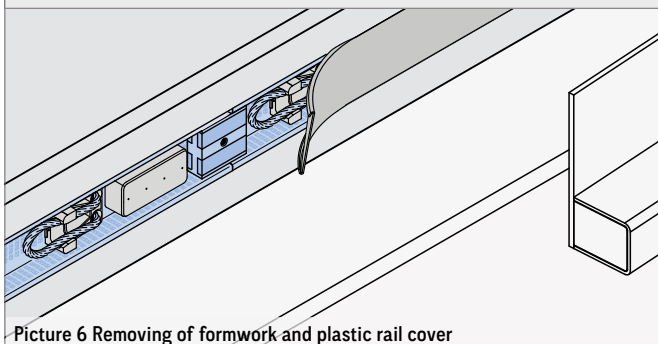

Picture 6 Removing of formwork and plastic rail cover

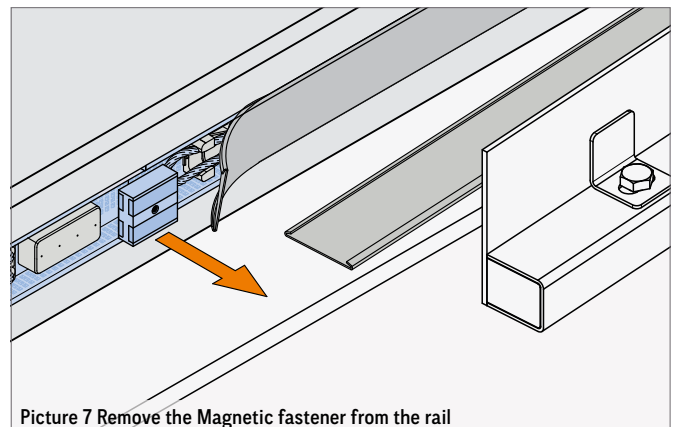

Picture 7 Remove the Magnetic fastener from the rail

After concreting, the formwork and rail cover can be removed easily.

The Magnetic fasteners can now be easily and quickly removed from the rail and reused.

# Magnetic fastener for connecting rails

## APPLICATION OF THE MAGNETIC FASTENER: 84MAX70 (E.G. FOR POWER DUO SYSTEM - 70 MM)

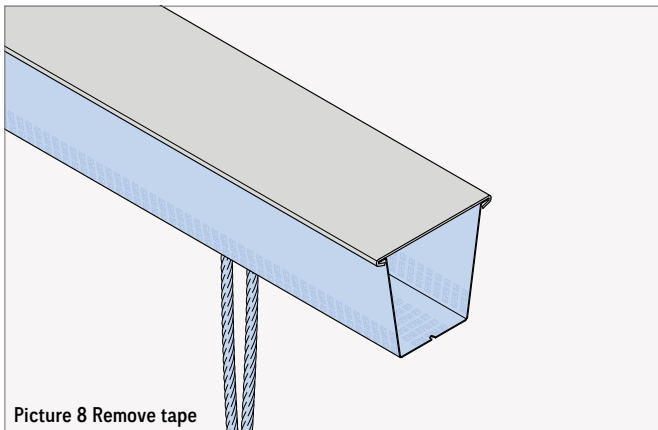

Picture 8 Remove tape

In order to insert the Magnetic fasteners into the rail the sealing (tape) at the end of the rails have to be removed.

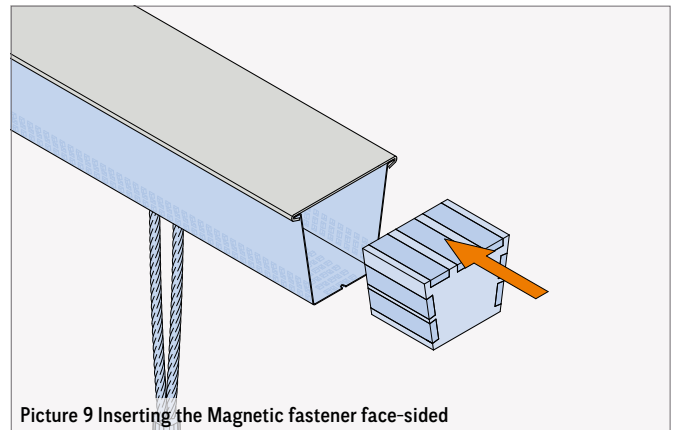

Picture 9 Inserting the Magnetic fastener face-sided

Now the Magnetic fasteners can be inserted face-sided into the sheet metal profile of the rail.



### INSTALLATION OF MULTIPLE CONNECTING RAILS

If multiple rails are installed in a row only one Magnetic fastener is required per rail joint. In this case, the rail joint must be sealed again with adhesive tape after installation on the formwork.

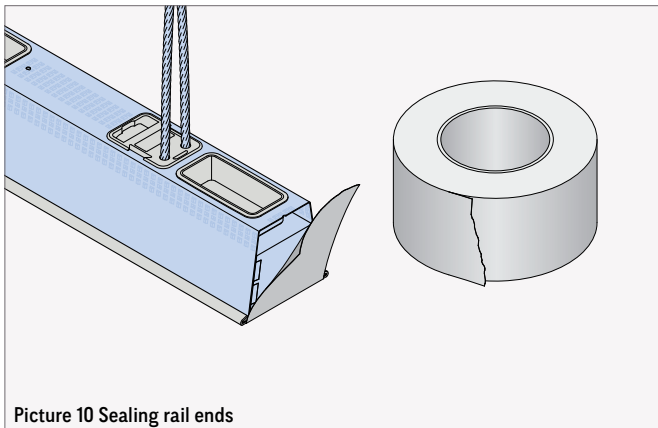

Picture 10 Sealing rail ends

Now, the rail ends are sealed tightly again, e.g. with adhesive tape.

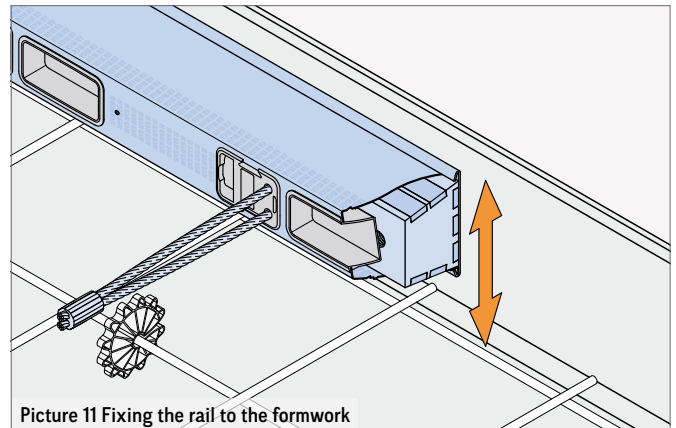

Picture 11 Fixing the rail to the formwork

Now, the rail with the Magnetic fasteners can be attached to the steel formwork. A correction of the rail position is possible at all times without any problems.



### REMOVING THE COVER

When removing the plastic cover, avoid damaging the Magnetic fasteners with tools (e.g. hammer).

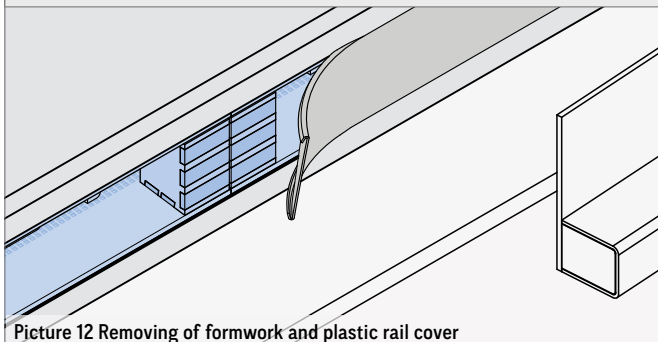

Picture 12 Removing of formwork and plastic rail cover

After concreting, the formwork and rail cover can be removed easily.

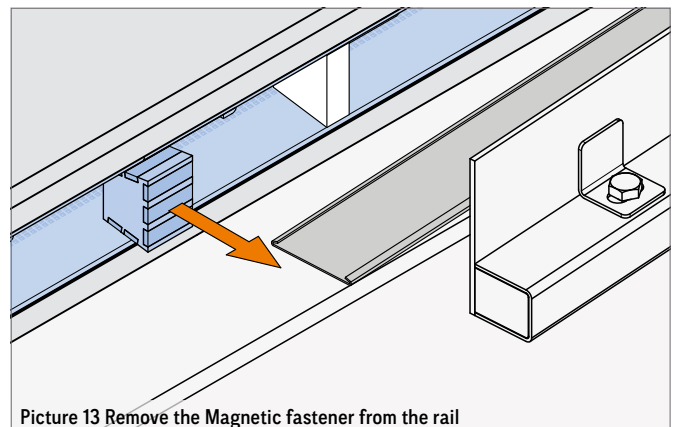

Picture 13 Remove the Magnetic fastener from the rail

The Magnetic fasteners can now be easily and quickly removed from the rail and reused.

## NOTES

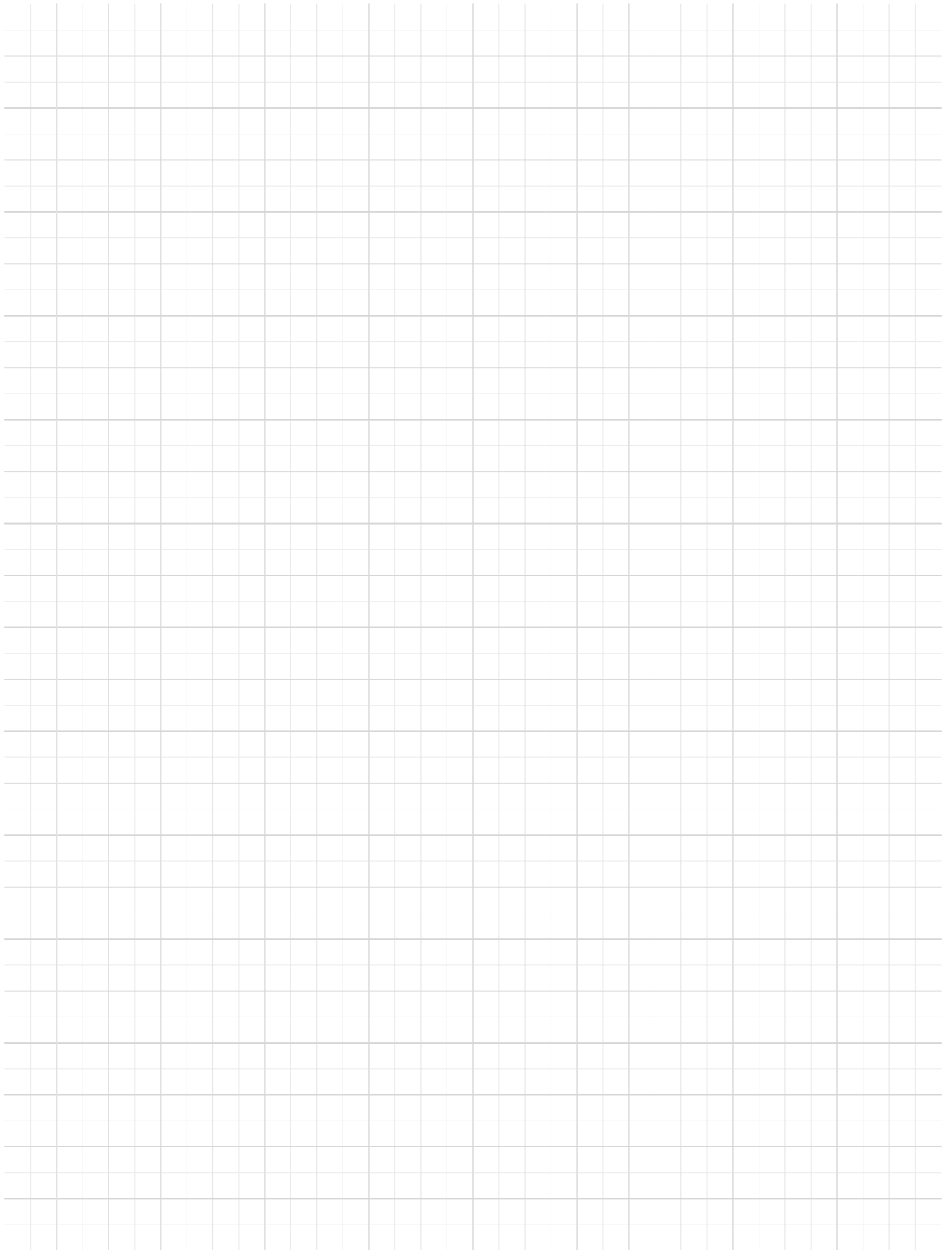



**PHILIPP GmbH**

Lilienthalstrasse 7-9  
63741 Aschaffenburg

☎ + 49 6021 40 27-0  
✉ info@philipp-gruppe.de

**PHILIPP GmbH**

Roßlauer Strasse 70  
06869 Coswig/Anhalt

☎ + 49 34903 6 94-0  
✉ info@philipp-gruppe.de

**PHILIPP GmbH**

Sperberweg 37  
41468 Neuss

☎ + 49 2131 3 59 18-0  
✉ info@philipp-gruppe.de

**PHILIPP ACON Hydraulik GmbH**

Hinter dem grünen Jäger 3  
38836 Dardesheim

☎ + 49 39422 95 68-0  
✉ info@philipp-gruppe.de



**PHILIPP Vertriebs GmbH**

Leogangerstraße 21  
5760 Saalfelden / Salzburg

☎ + 43 6582 7 04 01  
✉ info@philipp-gruppe.at



**Visit us!**

[www.philipp-group.de](http://www.philipp-group.de)